



model **6463**  
Drain Strainer

## FEATURES & BENEFITS

---

## OPTIONS

---

To see all options for this model, visit [www.hawSCO.com](http://www.hawSCO.com)



## SPECIFICATIONS

---

Model 6463 is a satin chrome-plated vandal-resistant waste strainer with anti-airlock draining feature. Includes fiber washer and locknut, 1-1/2" NPS. Used on the 1000 series type bowls.

## APPLICATIONS

---

THIS DOCUMENT IS TRUE AND CORRECT AT TIME OF PUBLICATION. CONTINUED PRODUCT IMPROVEMENTS MAKE SPECIFICATIONS AND MEASUREMENTS SUBJECT TO CHANGE WITHOUT NOTICE.

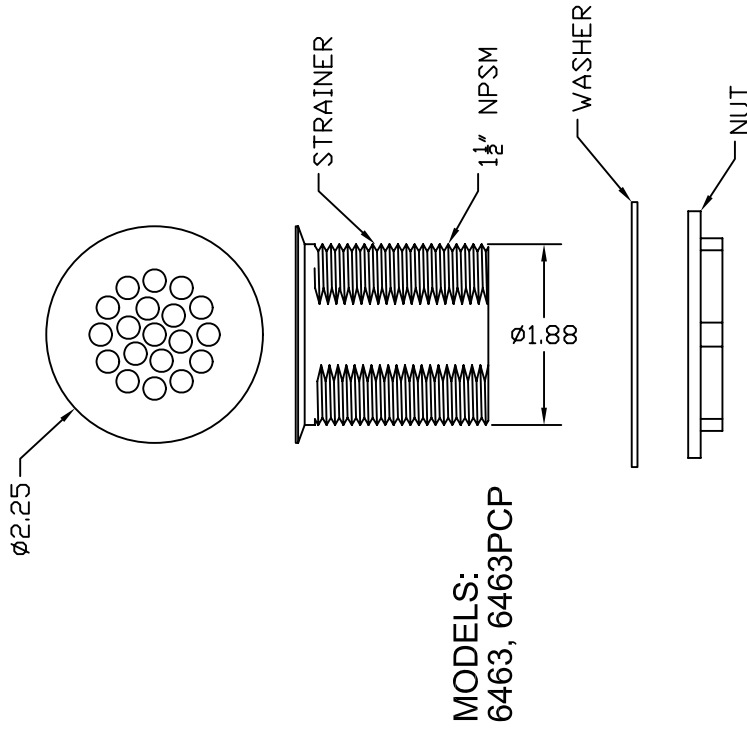
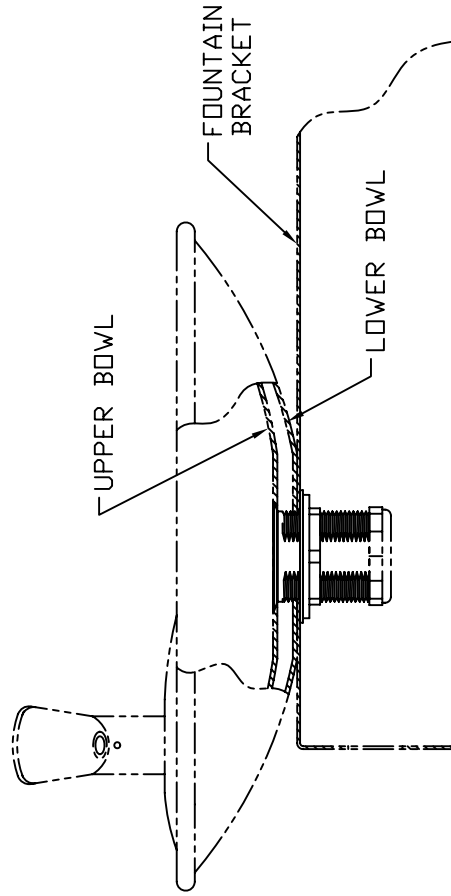

MODELS:  
6463, 6463PCP

## TYPICAL INSTALLTION

ACTUAL MODEL WILL VARY



INFO FAX : 1-888-FAX-HAWS (1-888-329-4297)  
1455 Kleppe Ln, Sparks NV, 89431  
Phone: 775-359-4712 Fax: 775-359-7424  
Haws Ag, Bachweg 3, CH-3401 Burgdorf Switzerland  
Haws Mfg Pte Ltd 74 Sungai Kadut Loop Singapore 729531  
e-mail: Haws@hawsco.com website: www.hawsco.com

FOR NO.	REVISED BY	DATE	DESCRIPTION
6463	ECN: 4054	12/27/99	BW
U.F.	DATE	SCALE	1:2
APPROVED:	DATE	SCALE	1:2
MODEL(S):	6463, 6463PCP	INFO FAX DOC #:	26463
DRAWING NUMBER:	14458000	INSTALLATION/BACK:	
SIZE:	A	SHEET:	1 OF 1